

Characterization of the spectral irradiance lamps at NMISA

Macdufe Mkabela^{1,2*}, Pieter Du Toit¹, Rheinhardt Sieberhagen¹, Walter Meyer²

¹ National Metrology Institute of South Africa, Private bag X34, Lynnwood Ridge, 0040, South Africa

² University of Pretoria, Private Bag X20, Hatfield, 0028, South Africa

E-mail: *mmkabela@nmisa.org

Abstract: This work investigates some of the uncertainty contributions to the spectral irradiance calibration of UV-C lamps. The radiometry concepts and the instrumentation used are addressed first. In ultraviolet (UV) spectroradiometry, spectral irradiance measurements have large uncertainties mainly due to a low signal-to-noise ratio (SNR) in the UV region; however other factors may also contribute to these high uncertainties. Therefore quantifying the sources of uncertainties is important to improve the accuracy of the measured results. We characterized a low pressure mercury lamp when compared to a tungsten halogen lamp when used as standards for spectral irradiance at the National Metrology Institute of South Africa (NMISA), in terms of stability, translation, and orientation. We found that the calibrations of the UV-C low pressure mercury lamps are not suitable as standard lamps for calibration of UV-C due to uncertainties introduced by orientation, translation and, instability effects of this lamp.

1. Introduction

Metrology is concerned with the accurate measurement of physical quantities and requires the determination of uncertainty of measurement. Radiometry is the field concerned with the accurate measurement of radiant energy (Q) across the entire electromagnetic spectrum (EMS), and the determination of how this energy is transferred from a source, through a medium, and to a detector [1]. Traditionally, radiometry assumes that the propagation of light can be modelled using the laws of geometric optics, and in practice radiometric measurements are limited to the optical (ultraviolet (UV), visible (VIS), and infrared (IR)) region. The International Commission on Illumination (CIE) divides the UV region into four regions (VUV, UV-C (200 nm – 280 nm), UV-B, and UV-A) based on the biological effects on microorganisms [2]. In this study we focus on the measurement of UV-C radiation of the EMS. The UV-C radiation is important because of its germicidal effectiveness on microorganisms in air and other media.

The use of radiation in the germicidal region can help combat the spread of mycobacterium tuberculosis (TB) and other microorganisms in South Africa, mainly at hospital in waiting areas and treatment rooms. This technology is referred to as air UV germicidal irradiation (UVGI) [3]. Accurate measurement of the UV-C radiation emitted by UVGI lamps is very important for the safety of staff and patients, and South African citizens in general.

The radiometric quantities of interest are introduced here. Radiometric quantities are usually wavelength dependent; the spectral quantities are radiometric quantities taken as a function of wavelength. The flux Φ emitted by the source incident on a surface per unit area dA of that surface is called irradiance E .

$$E = \frac{d\Phi}{dA}. \quad (1)$$

The measurement of spectral irradiance (measured in $\text{W}/\text{m}^2/\text{nm}$) of a lamp is performed with a spectroradiometer. The basic spectroradiometer consists of a monochromator, combined with a detector on the exit slit and an integrating sphere (IS) on the entrance slit. The measured result has an uncertainty associated with it, calculated using the uncertainty budget (UB). In this paper, we highlight some of the contributors to the uncertainty budget (UB) including the stability, orientation, and translation of the lamp.

2. Measurement method.

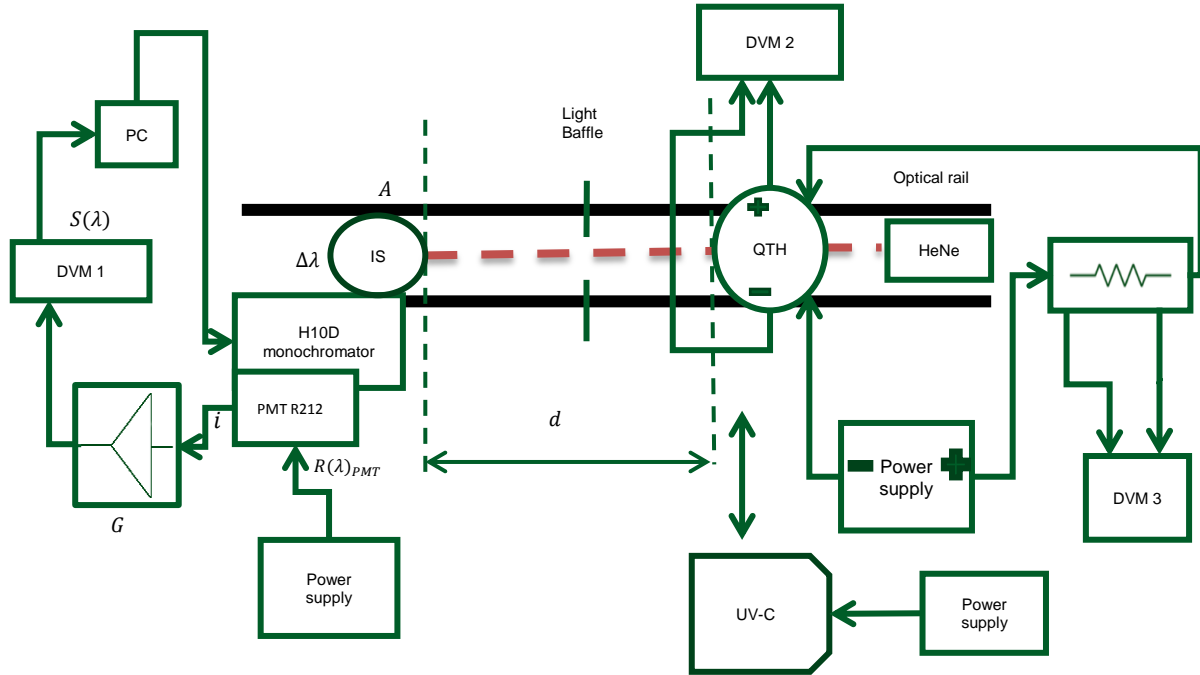

Figure 1: The measurement setup of the spectral irradiance lamp calibrations at NMISA. The setup makes use of a substitution method where one lamp is measured at a time.

The measurement setup in Figure 1 makes use of the substitution measurement method, which is a direct comparison with the value of a reference standard, having similar properties to the unit being measured (UUT) [4]. During an actual calibration, the spectral irradiance of a UUT (UV-C) is determined by a direct comparison with a calibrated spectral irradiance standard (QTH) lamp with known spectral irradiance using a spectroradiometer. During an actual calibration, the QTH standard lamp is measured at its respective position first and substituted with the UV-C lamp which is measured at a displacement position suitable for that calibration. The standard lamp is measured the second time to check repeatability. The measured voltage $S(\lambda)^{STD}$ is the measured spectral output voltage of the standard lamp and is modeled by

$$S(\lambda)^{STD} = E(\lambda)^{STD} R(\lambda) \Delta\lambda A. \quad (2)$$

Equation 2 can be explained as follows: $E(\lambda)^{STD}$ is the spectral irradiance emitted by a spectral irradiance standard lamp incident on the IS with an aperture area A , spectrally dispersed by a monochromator with a spectral bandwidth $\Delta\lambda$ falling onto the photomultiplier tube (PMT) detector, and the spectroradiometer has spectral irradiance responsivity $R(\lambda)$ which is a combination of IS throughput $\rho(\lambda)$, diffraction efficiency of monochromator gratings $M(\lambda)$, PMT response $R(\lambda)_{PMT}$, and the gain G of the amplifier (which converts the current signal from the PMT into a voltage signal). Similarly the spectral output voltage of the UUT $S(\lambda)^{UUT}$ is modeled by:

$$S(\lambda)^{UUT} = E(\lambda)^{UUT} R(\lambda) \Delta\lambda A. \quad (3)$$

where $R(\lambda)$, $\Delta\lambda$, and A remain the same during calibration since $E(\lambda)^{STD}$, $S(\lambda)^{STD}$, and $S(\lambda)^{UUT}$ are known, the spectral irradiance $E(\lambda)^{UUT}$ of the UUT can be determined from equations 2 and 3 as:

$$E(\lambda)^{UUT} = \frac{S(\lambda)^{UUT}}{S(\lambda)^{STD}} E(\lambda)^{STD}. \quad (4)$$

Equation 4 is known as the measurement equation for spectral irradiance calibration.

The spectral irradiance of lamps is influenced by lamp stability, translation, and orientation. Each uncertainty contributor is evaluated using a model associated with it. The stability of lamps was monitored by two temperature controlled silicon (Si) photodiode at time t , and the following model was used:

$$E(\lambda) = \frac{\Phi(t)}{A} \quad (5).$$

$\Phi(t)$ is the flux incident on the area A of the Si photodiodes detector surfaces, and $E(\lambda)$ is the spectral irradiance emitted by the lamp. The uncertainties associated with translation of lamps were quantified using the inverse square law of point source model as:

$$E = \frac{I}{d^2}. \quad (6)$$

Where d is the distance from the lamp to the IS, I is the lamp intensity, and E is lamps irradiance. The inverse square law is valid only when the light source approximates a point source. A lamp approximates a point source if the distance to the lamp is at least five times greater than the largest dimension of the source [5]. The uncertainties in orientation of the lamps were quantified using $I = I_\theta \cos \theta$ for a Lambertian distribution. θ is the angle between the optical axis and the direction of normal incidence for the spectroradiometer aperture. For a non Lambertian distribution, an alignment factor $(1 - \gamma)$ is determined individually for each lamp, with γ determined from the small variations of the direction with respect to the burning position and the direction of emittance as the average of repeated alignments [6]

The spectral irradiance unit is derived from the high temperature blackbody (HTBB) radiator which employ's Plank's radiation law [7]. In the UV region, a 1000 W quartz tungsten halogen (QTH) and a 30 W deuterium lamps are generally used as standard lamps [8,9]. The QTH lamp is the most commonly used transfer standard for spectral irradiance in the wavelength region 250 nm to 2500 nm due to their good stability and ease of use [10]. The QTH lamp used here was calibrated at a specified distance (500 mm in our case) while operating at a current of approximately 8.000 A. The current was measured with a standard resistor and DVM 3 in Figure 1 using Ohm's law while the stability of the lamp was monitored by measuring the terminal voltage (normally 120 V) using DVM 2. The QTH lamp distance was realized with a rod cut and calibrated to this specific distance.

The UUT is a UV-C low pressure (LP) mercury (Hg) lamp. Between the lamps and the IS, baffles were used to minimize stray light. The IS in front of the monochromator is used to minimize the polarization of the light source by a complete depolarization of lamps and is coated internally with a reflective material (BaSO_4) that has a spatially uniform and uniformly diffuse reflectance [11], with the aim to combine radiant flux. The direct irradiation of the monochromator by lamps is avoided due to resultant variation in the irradiance distribution in the monochromator [2]. A double grating monochromator with a very low stray light level was used to disperse light, with a bandwidth of 4 nm. Before the start of measurements, the wavelength scale of the monochromator was confirmed to be within its calibrated uncertainty using known spectral lines from a mercury (Hg) pencil lamp.

The spectrally dispersed light was detected by the PMT detector with a spectral response from 185 nm – 650 nm, and a maximum response at 340 nm [12]. The PMT was powered by a high voltage of 700 V for all measurements in this paper. A helium neon (HeNe) laser is used to align the optical instruments (lamps, monochromator, and baffles) on the optical rail.

3. Results and discussions

The spectral output voltage stability of the QTH and the LP Hg lamps was measured with a spectroradiometer at 10 minutes interval after the lamps had been warmed-up. The low radiation output of the QTH lamp in the UV-C region, results in a low signal-to-noise ratio (SNR). As a result, the QTH lamp uncertainties were quantified in the visible region (441.5 nm and 450.5 nm) with the assumption that, the effect in orientation and translation on the output signal was the same at UV-C wavelengths. The LP Hg lamp however had a high output resulting in a significant signal around 251 nm to 255 nm as expected because of the Hg peak at 253.66 nm, and the uncertainties were quantified at 255 nm. The output stability of the two lamps was also monitored by two temperature stabilized UV-enhanced Si photodiodes at 10 minute intervals, for an independent indication of lamp stability and the results are tabulated in Table 1.

Table 1: The input electrical voltage (U) of the QTH lamp and the spectral output voltage (S) stability of both lamps.

Time [min]	t_1 (0 min)	t_2 (10 min)	t_3 (20 min)	σ	U_{xi} [%]
QTH voltage (U) [V]	113.29	113.27	113.24	2.56E-02	0.02
QTH lamp current (J) [A]	8.00017	8.00022	8.00028	5.15E-05	0.001
Si -QTH (Φ) [A]	1.5174	1.5173	1.5171	8.99E-03	0.01
Si-LP Hg (Φ) [A]	0.0142	0.01419	0.01409	5.37E-01	0.5

The symbols used in Table 1 are defined as follows: t is the time in minutes at which measurements were taken, σ is the standard deviation of the measurements in Table 1, and U_{xi} is the relative uncertainties in percentage calculated by dividing the σ with the average of t_1 , t_2 and t_3 . U is the QTH lamp voltage measured in volts directly at DVM 2 in Figure 1 simultaneously with the QTH lamp current J measured in amperes as calculated from the voltage across DVM 3 and the standard resistor. Si-(Φ) is the output signal of the lamps monitored with the Si photodiodes detectors.

The input electrical voltage stability of the QTH lamp was measured using a four wire technique directly from DVM 2 (Figure 1) at 10 minute intervals simultaneously with the lamp time stability (measured with the spectroradiometer) and the lamp output monitored with the Si photodiodes. The time stability of the QTH standard lamp had a calculated relative uncertainty of 0.5 % compared to 3 % of the LP Hg UV-C lamp. The measured input electrical voltage of the QTH standard lamp on average was 113.27 V compared to the calibration certificate value of 113.11±0.03 V. The +0.13 V observed drift from the certificate value was speculated to be due to temperature effects of the DVM 2. The monitored lamps output of the QTH standard and LP Hg UV-C lamps with the Si photodiodes on average showed that the QTH standard lamp was more stable with a relative uncertainty of 0.01 % compared to 0.5 % of the LP Hg UV-C lamp. The Si photodiodes detectors results agreed with the time stability results, where the QTH standard lamp was in both cases more stable than the LP Hg UV-C lamp as expected.

A point source approximation was tested for both lamps (Figures 2 and 3). As expected, in both wavelengths (441.5 nm and 450.5 nm), the QTH lamp closely approximated a point source except for positions closer than 500 mm (400 mm and 300 mm). Because of the large dimensions of the LP Hg lamp it deviated from the point source approximation. We used the inverse square law of point sources Equation 6 as our model to calculate the theoretical values in Figures 2 and 3. The effect of orientation (or rotation around vertical axis) was measured at the calibrated positions of the lamps. The QTH lamp is close to symmetric; therefore, theoretically, the orientation of the QTH lamp should not have significant effect on the output signal. The difference in spectral output voltage (expressed as a percentage) produced by the lamps when displaced by 1 mm from their calibrated positions is shown in Table 2.

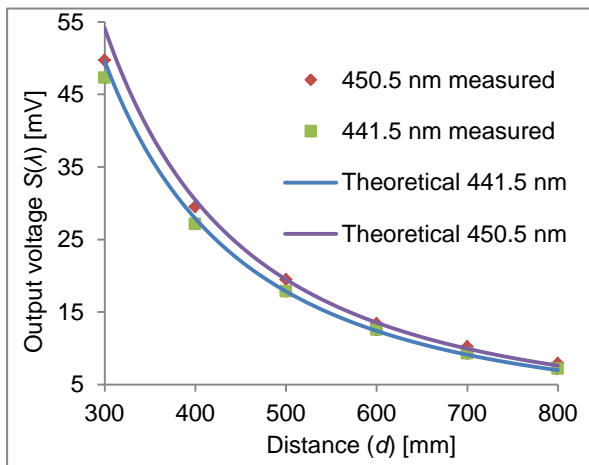

Figure 2: The point source approximation of the QTH lamp at 441.5 nm and 450.5 nm.

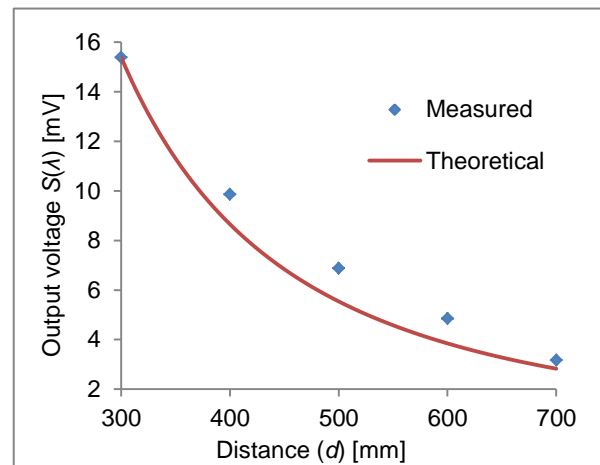

Figure 3: The point source approximation of the LP Hg lamp at 255 nm.

The 1 mm distance was chosen because with the setup at NMISA we are confident that we cannot make an error of more than 1 mm when positioning our lamps. Hence, only the effect in spectral output voltage generated by 1 mm (the worst case for each lamp) will be included in the UB. -1 mm, was when the lamps were moved closer to the spectroradiometer and +1 mm was further away from the spectroradiometer. The lamps were very sensitive to translation. For +1 mm displacement, the QTH lamp showed 0.1 % effect which was higher than 0.01 % for the LP Hg lamp

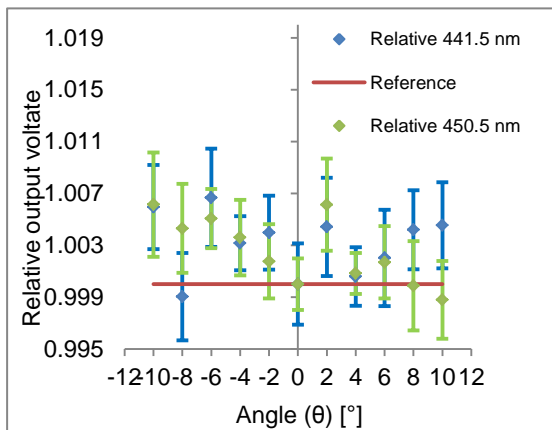

Figure 4: The orientation effect of the QTH lamp at 441.5 nm and 450.5 nm.

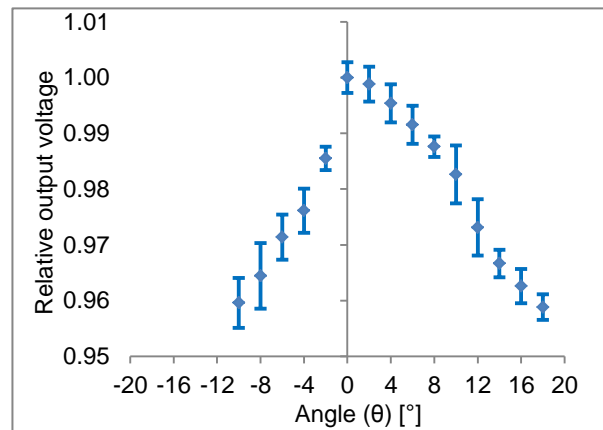

Figure 5: The angular dependence of the LP Hg lamp at 255 nm.

The LP Hg UV-C lamp had two lamp tubes mounted parallel to each other emitting light equally in all directions, but they are mounted in front of a reflector that reflects light towards the front of the lamp. Because of this, the LP Hg UV-C lamp was expected to have higher angular dependence than the QTH standard lamp. The effect of orientation of both lamps is shown graphically in Figures 4 and 5 and the calculated relative uncertainties are summarised in Table 3. As expected the QTH standard lamp had a smaller angular dependence compared to the LP Hg UV-C lamp. Furthermore, the LP Hg UV-C lamp showed an asymmetric distribution, probably due to misaligned lamp tubes or lower output from one of the lamp tubes. With the spectroradiometry setup at NMISA, we are confident that

the lamps orientation cannot be misaligned by more than 2 °, hence, only the relative uncertainties in the spectral output voltage caused by a 2 ° misalignment were included in the UB for both lamps.

Table 2: The translation effect of the QTH and LP Hg lamps.

Distance [mm]	QTH lamp 450.5 nm	LP Hg lamp 255 nm
+1	-0.07 %	-0.01 %
-1	0.9 %	0.8 %

Table 3: The orientation effect of the QTH and LP Hg lamps.

Position [°]	QTH lamp 450.5 nm	LP Hg lamp 255 nm
+2	0.4 %	-1.5 %
-2	0.6 %	-0.8 %

4. Conclusions and future work

The spectral irradiance measurement setup was characterized for translation, orientation and stability. The QTH lamp was more stable compared to the LP Hg UV-C lamp when monitored with Si photodiodes detectors. Also, the QTH lamp showed a long term drift from the lamp voltage with the lamp current very stable at 8.0002 A ± 0.0006 A. The effect of translation had a calculated relative uncertainty of 0.8 % for a 1 mm displacement from the calibrated positions for both lamps. For a 2 degrees misalignment from the optical axis, the QTH measured output signal changed by maximally 0.6 % while the LP Hg lamp changed by 1.5 %, which indicated an expected high angular dependence.

For future work, the deuterium lamp will also be characterized for translation, orientation, and stability. Due to its high spectral irradiance, the deuterium lamp is an ideal lamp to use as standard in the UV-C region. It will be investigated for use as a working standard or a primary standard. We will also test the systems temperature dependence with respect to the laboratory ambient conditions during measurements.

5. References

- [1] Zalewski E F 1995 *Radiometry and Photometry Handbook of Optics Vol 2* (Dunbury: Hughes Dunbury Optical Systems) pp 24-73
- [2] CIE 1989 *International Lighting Vocabulary* (Vienna: Central Bureau of the Commission Internationale de l'Eclairage)
- [3] Kowalski W 2010 *UVGI handbook: UVGI for air and surface disinfection* (New York: Springer Science & Business Media) pp 1-12
- [4] Sauter G and Goodman T 2011 *Determination of measurement uncertainties in Photometry SP1 1* (Vienna: Commission Internationale De L'Eclairage CIE Central Bureau) p 4
- [5] Ryer A 1997 *The light measurement handbook* (Peabody: International Light Technologies) pp 26-7
- [6] Schanda J (Ed) 2007 *Colorimetry: Understanding the CIE system* (New Jersey: John Wiley & Sons) pp 376-83
- [7] Planck M 1901 On the law of distribution of energy in the normal spectrum *Annals of Physics* **4** p 553
- [8] Woolliams E R, Fox N P, Cox M G, Harris P M and Harrison N J 2006 Final report on CCPR K1-a spectral irradiance from 250 nm to 2500 nm *Metrologia* **43** 1A 02003
- [9] Sperfeld P 2008 Spectral irradiance 200 nm to 350 nm *Report of the CIPM key comparison CCPR-K1.b*
- [10] Sanders C L and Rotter R 1984 *The Spectroradiometric Measurement of Light Sources* (Paris: Bureau central de la CIE) p 47
- [11] Kostkowski H J 1997 *Reliable Spectroradiometry* (La Plata: Spectroradiometry Consulting) pp 247-9
- [12] Photomultiplier Tube R212 TPMS1041E01 June 1998 Hamamatsu Photonics K K downloaded 11 March 2016 <http://pdf.datasheetcatalog.com/datasheet/hamamatsu/R212.pdf>