

Analysis and Performance of a closed loop external cavity diode laser control system

Victory Opeolu¹, Kessie Govender², Adrian Wyngaard², Ouassini Nemraoui³, Gerhard De Jager⁴, and Jordan Scarrott²

^{1,2,3}Department of Electrical, Electronic, Computer and Mechatronics Engineering, Cape Peninsula University of Technology, Symphony Way, Bellville, Cape Town, 7535, South Africa

⁴Department of Electrical Engineering, University of Cape Town, Rondebosch, 7701, South Africa

E-mail: ¹opeolu.victory@gmail.com

Abstract. External cavity diode lasers (ECDL) are commonly used in laser cooling experiments involving rubidium atoms. The laser frequency is finely tuned by adjusting the cavity length and the diode current. This is done by locking the ECDL to an appropriate rubidium transition using a saturation absorption Spectroscopy (SAS) setup together with a proportional-integral-derivative (PID) controller. In this paper, we give an overview of the analysis and performance of the closed loop control system using theoretical and numerical modelling as well as approaches used to create a system model.

1. Introduction

Semiconductor diode lasers, first demonstrated in laboratories more than forty years ago, have become a crucial part of modern technology. They are widely used for telecommunication, precise measurements, medicine, laser absorption spectroscopy and so much more. Automatic control has also come a long way since James Watt's centrifugal governor for the speed control of a steam engine. It has become crucial in science and engineering systems such as missile guidance, aircraft-piloting systems, etc. Automatic control provides a means for attaining optimal performance of dynamic systems [1].

Laser diodes are primarily developed for applications in wavelength division multiplexing (WDM) technology, coherent communication systems and sensing in precise measurements [2]. They are also used in atomic spectroscopy but more recently, they are used in laser cooling of atoms. This involves the cooling of atomic and molecular samples to near absolute zero using one or more laser fields. Doppler cooling is the most common method and is used to cool low density gases (e.g. rubidium) down to the microkelvin range. Lasers needed for cooling need to be precisely controlled to successfully get precise and accurate results. This is achieved by locking the laser frequency to specific atomic transitions of the chosen gas [3].

Although laser diodes have been used in laser cooling experiments, however, very little has been done with regards to analysis of closed loop feedback systems using external cavity laser diodes. There has been some analysis done but there were analytical in nature and focused only on the laser diodes [4, 5], not on the control system. [4] does provide some analysis of laser control using saturated absorption spectroscopy but they are modelled based on laser rate

equations. This paper discusses the performance of a closed-loop control system for locking an external cavity diode laser.

2. System Components

Figure 1 shows a general overview of the system to be modelled. It consists of a PID controller, an external cavity diode laser and a feedback setup in the form of a saturated absorption spectroscopy experiment. The solid lines represent voltages and the dashed lines represents the laser beam.

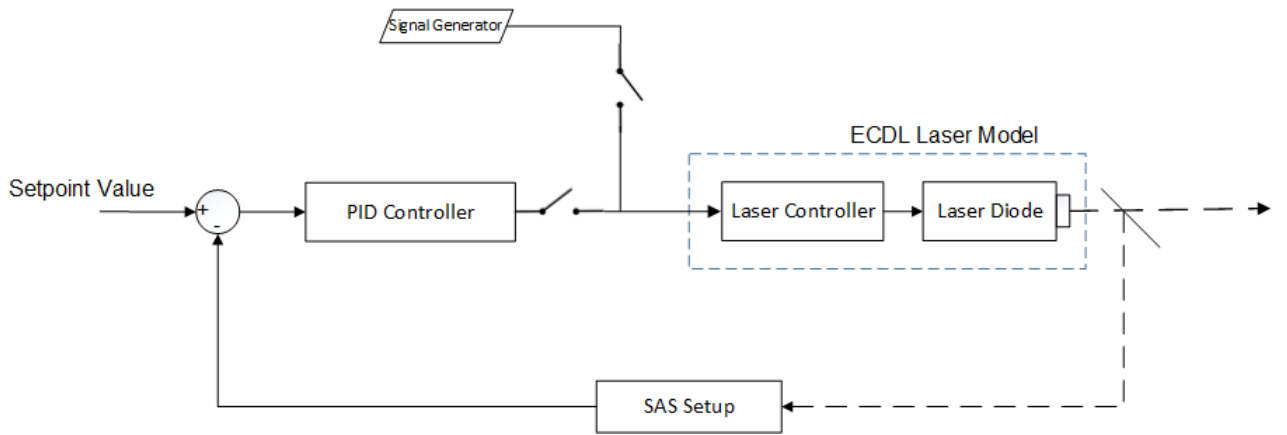

Figure 1. Overall block diagram of the laser control system

2.1. External Cavity Diode Laser (ECDL)

The ECDL primarily consists of a semiconductor diode laser cavity with reflective coatings on one facet, the other facet being the side at which the light emerges, a collimator for coupling the output of the diode laser and an external mode-selection filter [2]. The diode is placed in an external cavity, the length of which is controlled using a piezoelectric device. The resonant frequency of the cavity is given by $F = cn/L$, where c is the speed of light, n is an integer and L is the cavity length.

2.2. Saturated Absorption Spectroscopy (SAS)

The feedback consists of a saturated absorption setup which acts as the sensing element of the system. This setup produces an output signal that is proportional to the laser frequency, depending on where this frequency is compared to a particular hyperfine response. This response function is a Lorentzian curve. The saturated absorption spectroscopy setup is used to counteract the thermal motion of the atoms, thus producing a true Lorentzian output. More details on saturated absorption spectroscopy can be found in [3, 6].

When the laser frequency is scanned across the atomic transition range, we obtain a response similar to that shown in Figure 2 and each of these peaks has a Lorentzian shape such as that shown in Figure 3. In doppler cooling, the aim is to lock onto one of the hyperfine peaks.

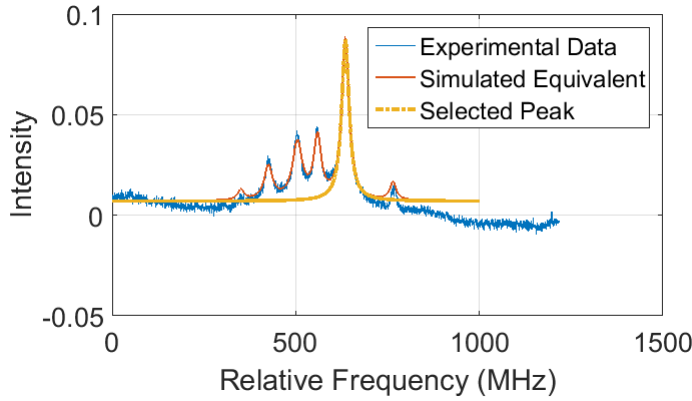

Figure 2. Hyperfine Structure of ^{85}Rb , $F = 3$ to $F' = 1, 2, 3$ [7]

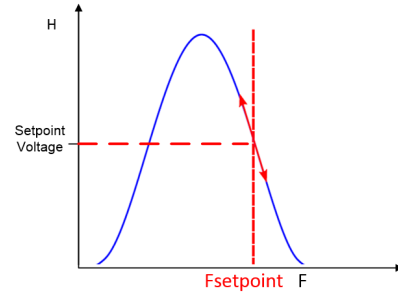

Figure 3. Typical Lorentzian curve

For our simulations, we use a series of Lorentzian curves to represent the feedback characteristic of the closed loop system. We try to lock onto one side of the curve as shown in Figure 3.

2.3. PID Controller

PID control is the most commonly used control algorithm. The coefficients: proportional, integral, and derivative are varied to get the optimal response from a system [1]. The difference between the setpoint value and the output of the saturated absorption spectroscopy setup (the difference/error signal) is determined. The error signal is amplified, integrated (and sometimes differentiated) before being fed back to the piezoelectric device.

3. Simulation Analysis

Figure 4 shows the control model of the system.

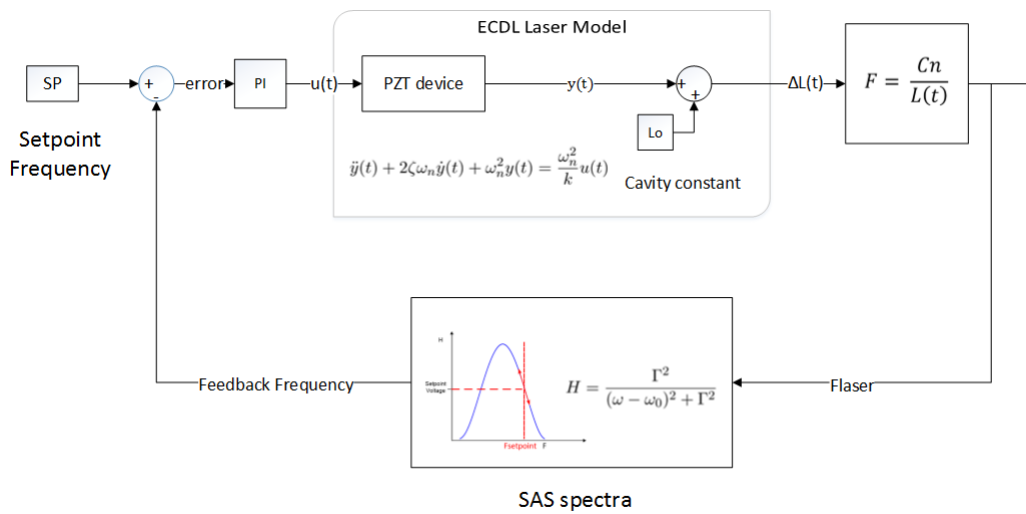

Figure 4. ECDL Frequency Control Model

The external cavity diode laser has a piezoelectric device that behaves as a Mass-Spring-Damper system. When a force (input voltage) $u(t)$ is applied to the piezoelectric crystal, its atoms are slightly displaced from their initial positions, thus creating a change in cavity length [8]. The relationship between the displacement Δy and the input force $u(t)$ can be represented by the differential equation:

$$\ddot{y}(t) + 2\zeta\omega_n\dot{y}(t) + \omega_n^2 y(t) = \frac{\omega_n^2}{k} u(t) \quad (1)$$

where ω_n is the resonant frequency, k is the stiffness of the crystal, ζ is the damping ratio and u is the input voltage.

We rewrite the above as:

$$\ddot{y}(t) + Ay(t) + By(t) = Cu(t) \quad (2)$$

where $A = 2\zeta\omega_n$, $B = \omega_n^2$ and $C = \omega_n^2/k$.

We calculate the displacement y using two difference equations:

$$\dot{y}_1 = y_2; \quad (3)$$

$$y_2 = Cu(t) - Ay_2 - By_1; \quad (4)$$

where $y_1 = y$ in (2).

To solve this system, we use the Euler method as follows:

$$y_1(n) = \Delta t * y_2(n-1) + y_1(n-1) \quad (5)$$

$$y_2(n) = \Delta t * (Cu(n-1) - Ay_2(n-1) - By_1(n-1)) + y_2(n-1) \quad (6)$$

The rate of change of displacement $\Delta y_1(t)$ in the device influences changes in the cavity length of the laser, ΔL , which in turn controls the laser frequency.

We model the saturated absorption spectroscopy curve using a series of Lorentzian curves with each curve described by:

$$H = \frac{\Gamma^2}{(\omega - \omega_0)^2 + \Gamma^2} \quad (7)$$

where Γ is the width of the absorption curve shape, ω_0 is the resonant atomic transition frequency and ω is the laser frequency. ω in this case is the *F_laser* as shown in Figure 4

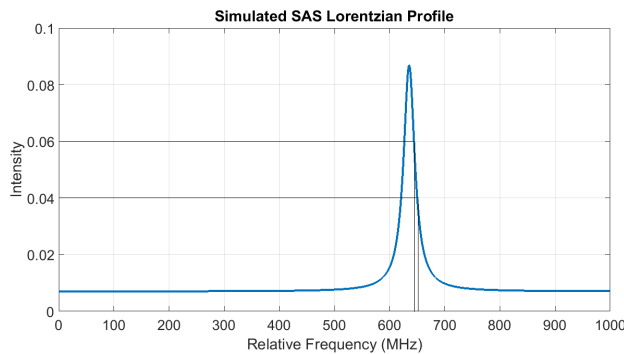

Figure 5. Simulated Lorentzian curve

We define the Lorentzian with results obtained from a saturated absorption spectroscopy (SAS) experiment. The Lorentzian curve, as shown in Figure 5 represents one of the hyperfine peaks shown in Figure 2. We choose a setpoint on the curve that corresponds to a certain laser frequency (on the right side of the curve). We simulated our system choosing two setpoint values 0.04 and 0.06, which corresponds to 645.9 MHz and 641.5 MHz respectively as seen in Figure 5. The feedback signal is subtracted from the setpoint value to get the steady state error. The PID block amplifies the error signal, integrates and implements differentiation, and its output (a summation of all three coefficients) is fed back to the piezoelectric device as a voltage input, making it a closed loop system.

4. Results and Analysis

Assuming the laser's initial undisturbed frequency is 648 MHz, we simulate the system to check its response to a step input from 643.5 to 645.9 MHz and 641.5 MHz respectively. The results are shown in Figure 6.

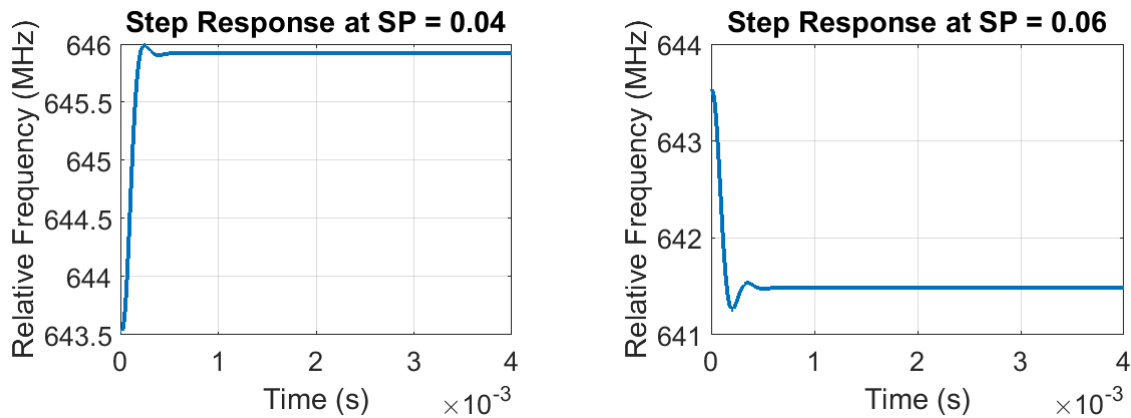

Figure 6. Step response of system

In a spectroscopy experiment various factors may affect the stability of the laser frequency such as the laser current, temperatures of the laser and its mount, air pressure, vibration and so on. We simulate these external factors in the form of disturbances in Figures 7 and 8. We first added a disturbance in the form of an impulse at a certain point in time for each setpoint frequency and the results can be seen in Figure 7.

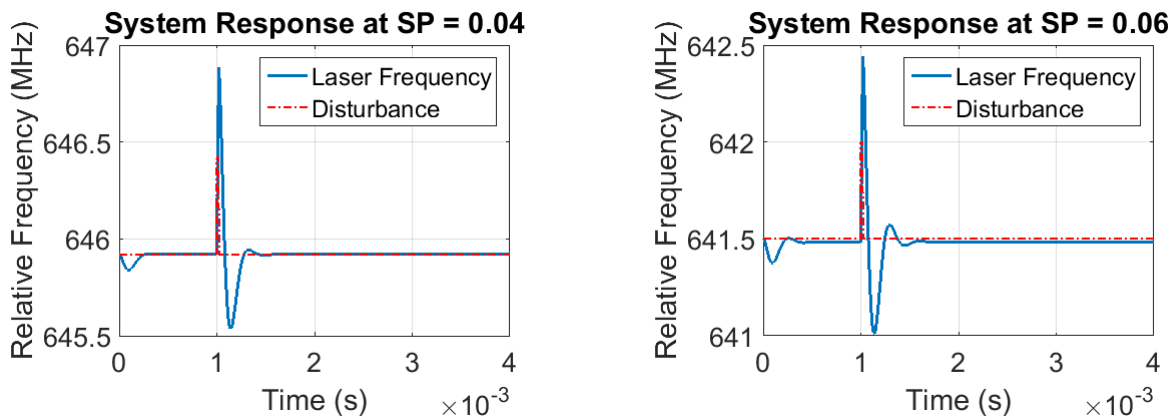

Figure 7. System response to impulse disturbance

The impulse disturbance implies the system had a random external influence at a certain point in time e.g. someone touched the laser head while the experiment was running. After adding a impulse disturbance, we notice the model behaves as an underdamped system. It first overshoots then settles down back to the specified setpoint (645.9 MHz and 641.5 MHz).

We also simulate external factors that may influence the laser frequency over a long period of time (e.g. a sudden rise in temperature of the laser mount) by adding a pulse disturbance over a chosen sample range (1000 \sim 2500 samples). Our results in Figure 8 show the laser frequency is still controlled to the setpoint values despite the disturbance occurring over a long period of samples.

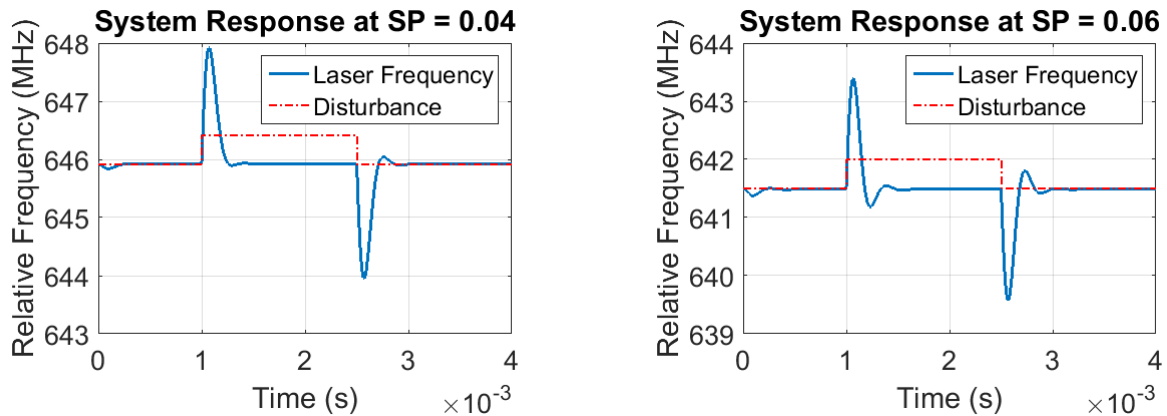

Figure 8. Plots with a pulse disturbance at a specific time sample range

5. Discussion and Conclusions

Numerical analysis of the closed loop system was implemented in Matlab using model parameters closely resembling those of the experiment. However for numerical reasons, the laser frequency was chosen to be a lot lower.

The Simulation showed that the system is slightly underdamped, with oscillation in the output dying within one or two oscillations. The system is capable of responding to slip changes i.e. the output follows the input as the setpoint is varied. In the case of sudden disturbances, the system is able to return to the initial state it was before the disturbance is applied.

More accurate representation of actual experimental parameter will be needed in the model for comparing experimental data.

References

- [1] Ogata K 1970 *Modern Control Engineering* (New Jersey: Prentice-Hall, Inc.)
- [2] Cunyun Y 2004 *Tunable External Cavity Diode Lasers* (Texas: World Scientific Publishing Co.) p 4
- [3] Weel M and Kumarakrishnan A 2002 *Can. J. Phys.* **80** 1449–1458
- [4] Genov G, Lellinger T E, Halfmann T and Peters T 2017 *J. Opt. Soc. Am. B* **34** 2018–2030
- [5] Debs J E, Robins N P, Lance A, Kruger M B and Close J D 2008 *Appl. Opt.* **47** 5163–5166
- [6] Preston D W 1996 *Amer. J. of Phys* **64** 1432–1436
- [7] Wyngaard A 2017 Experimental study of the weak field zeeman spectra of ^{85}Rb and ^{87}Rb (*Preprint SAIP Conference proceedings*)
- [8] Bentley J P 1995 *Principles of Measurement Systems* (New York: Longman Scientific & technical) p 163