

Using optical tweezers to measure the forces exerted by molecular motors in onion cells

A Erasmus, GW Bosman, PH Neethling and EG Rohwer

Laser Research Institute, Physics Department, Stellenbosch University, Private bag X1, Matieland, 7602, South Africa

E-mail: 16529138@sun.ac.za

Abstract. Optical tweezers enable the application of piconewton forces on a microscopic particle inside living cells. This allows for a particle to be spatially manipulated in three dimensions. In this study, the optical tweezers are used to investigate the forces needed to stall the motion of vesicle-carrying molecular motors in onion (*Allium cepa*) cells. The optical tweezers were constructed and the trap strength was calibrated. An integrated microscopy imaging setup was used to see and trap vesicles transported by molecular motors in the cells. The force calibration was then used to determine the intracellular forces of the molecular motors.

1. Introduction

Optical tweezers have been well established in biological and biophysical laboratories [1]. The optical trapping and tweezing of particles is possible due to the fact that light can apply radiation pressure on particles [2]. In this work a stable, single beam optical trap is constructed and used to trap particles with a higher refractive index than their surrounding medium.

For particles that are much larger than the wavelength of the trapping light, geometric ray optics can be used to describe the optical trapping. As light propagates through the particle refraction occurs and the light exiting the particle will have a different direction and thus momentum (Δp_{light} - see figure 1). The change of momentum of the light is away from the optical axis because the particle has a higher refractive index than the surrounding medium ($n_1 > n_2$). Due to conservation of momentum, the particle will experience a change of momentum and a force towards the optical axis ($\Delta p_{particle}$).

Light incident onto the particle will also scatter off the particle and induce a scattering force in the forward direction of the beam. The particle will therefore travel along the beam path. To overcome the scattering force and create a stable trap to keep the particle stationary along the optical axis, the trapping force must be increased sufficiently. This is achieved by arranging the rays in a converging manner, which translates to using a focused beam in an experimental setup. This is equivalent to creating an electric field with a steeper gradient thus producing a larger trapping force.

In this work an optical tweezers was constructed to measure the stall forces of molecular motors in onion (*Allium cepa*) cells. In the cell, molecular motors transport vesicles along the cytoskeleton (microtubules or actin filaments). Vesicles are spherical structures, encased by a lipid bi-layer, that hold proteins, nutrients, etc. Molecular motors assist with the efficient delivery of the above mentioned products in the cell by ‘walking’ along the cytoskeleton [3].

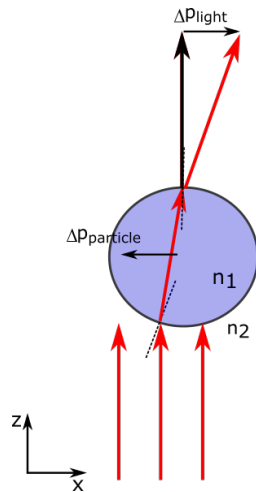

Figure 1. A particle in a laser beam will experience a force towards the optical axis ($\Delta p_{particle}$) due to the refraction of the transmitted light.

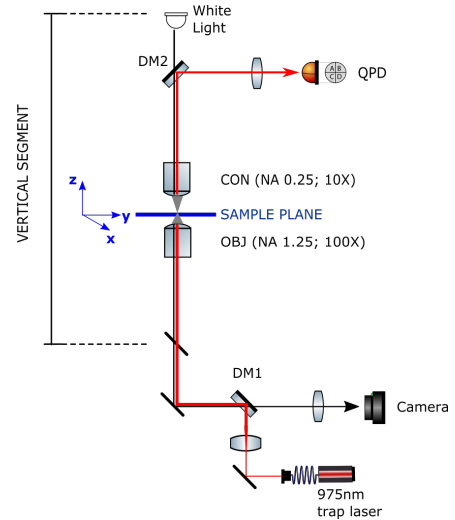

Figure 2. The optical tweezers setup is shown schematically here. The trap is created by focusing a 975 nm diode laser using a high numerical aperture microscope objective (NA of 1.25). A white light LED is used for wide field imaging.

The vesicles have a higher refractive index than the cytosol and it is therefore possible to trap them using the optical tweezers. Vesicles transported by molecular motors are identified by observing vesicles moving along a linear path, assumed to be the cytoskeleton, at a near constant speed. The force needed to trap the vesicle gives a measure of the force with which the molecular motor transports the vesicle.

In order to determine the force needed to stall the motion of a vesicle carried by molecular motors, the force that the optical tweezers exert on a trapped particle must be determined. This is done by trapping silica beads of similar size to that of the vesicles and using the power spectrum method [4].

Power spectrum method A particle in the optical trap can be modeled as a driven damped harmonic oscillator where the motion of the particle is driven by its Brownian motion in the medium it is suspended in. The restoring force that the particle in the trap experiences for a displacement x can be approximated by $F = -kx$. Here k is the trap stiffness constant which can be determined using the power spectrum of the variance of the displacement of the particle's position in the trap, which is measured on a position sensitive detector. From the power spectrum the corner frequency $f_c = \frac{k}{2\pi\gamma}$ can be determined (where $\gamma = 6\pi\eta r$ is the viscous drag coefficient), and so too the trap stiffness constant. Here η is the viscosity of the water (1.012 mPa.s) and r is the radius of the trapped particle. Figure 3 shows the signal from the position sensitive detector for the x coordinate, for a 1 μm bead's position in the trap, as well as the corresponding power spectrum. The corner frequency is indicated on the figure.

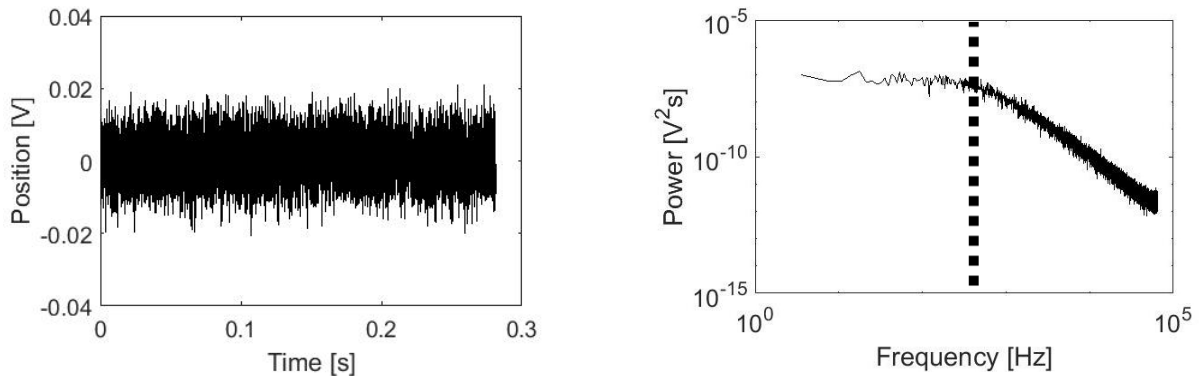

Figure 3. On the left, the position sensitive detector’s signal for the x coordinate shows the displacement of a $1 \mu\text{m}$ bead’s position in the trap due to Brownian motion. The corresponding power spectrum is shown on the right with the corner frequency, that can be calculated, indicated by a dotted line.

2. Experimental setup

Figure 2 shows a brief schematic of the optical tweezers setup used in this work. A narrow bandwidth near-infrared laser (wavelength of 975 nm) is used since this wavelength reduces local heating as the samples are predominantly transparent in the near infrared region.

The laser light is coupled into a single mode optical fiber and expanded to ensure optimal filling of the back aperture of a high numerical aperture (NA of 1.25) 100X oil immersion microscope objective. The sample is placed on a cover slide and its position is controlled with a computer controlled 3-axis piezo translation stage with 5 nm step resolution.

The transmitted trapping beam is collected by a condenser lens (10X, NA 0.25). The trapping light is reflected by a dichroic mirror (DM2) and imaged onto a quadrant position detector (QPD).

The movement of a trapped bead relative to the trap center is measured on the quadrant position detector. The temperature of the sample is monitored and measurements are conducted under constant temperature conditions to ensure that the viscosity of the fluid remains constant.

The optically trapped particle in the sample is imaged onto a CMOS camera using a white light LED as a light source and a 150 mm focal length bi-convex tube lens.

For force calibration measurements, dielectric silica beads of average diameter $1.01 \mu\text{m} \pm 0.09 \mu\text{m}$ was used. These beads were suspended in distilled water at a low concentration to avoid trapping multiple beads simultaneously.

Onion cell samples are prepared by removing a single layer of cells from the membranous outer layer of the onion, and fixing this layer on a microscope cover slide. The sample is placed at the focus of the objective and the vesicles are observed by imaging them on the camera.

The power in the trap was measured before the light enters the objective and it is assumed that the light lost through the objective is negligible. By measuring the force exerted by the optical tweezers at various incident powers, a force calibration curve of the trap strength versus incident laser power can be determined. This is used to determine the stall forces of vesicle-carrying molecular motors.

3. Results and discussion

Using the optical tweezers setup described above, silica beads of $1 \mu\text{m}$ in diameter were trapped. Figure 4 shows frames of a video of the trapped bead held stationary while freely diffusing beads

in its surrounding are moved towards the left with respect to the trapped bead.



Figure 4. This figure shows the movement of a trapped 1 μm bead (circled in white) relative to the other freely diffusing 1 μm beads (circled in black). This is achieved by moving the sample to the left while the trap position remains stationary.

The force calibration was completed as described above and the results are shown in figure 5. The trap constant, k , is shown to increase linearly along the x and y axes of the trap as the power in the trap increases. The parabolic approximation of the trap potential holds for a displacement equal to the length of the radius of the particle [5]. Therefore, for a 1 μm diameter particle typical forces are determined for a 0.5 μm displacement of the particle from the trap center. The trap exerts forces in the piconewton range on the particle (using $F = -kx$). For example, a 1 μm silica bead displaced 0.5 μm from the trap center experiences a restoring force towards the trap of 29 pN ($k = 5.8 \times 10^{-5}$ N/m) along the y axis of the trap when the trap power is 0.1 W, which is in good agreement with literature [6]. The difference in trap stiffness along the x and y axes is due to astigmatism of the focus.

The optical tweezers was then used to trap vesicles in onion cells and to determine the stall forces of molecular motors in the cell. It was assumed that the viscosity of the cytosol is similar to that of water [7]. The diameter of the vesicles were measured to be between 0.42 μm to 1.12 μm . This is of the same size as the beads used to calibrate the trap. The refractive index of the vesicles is assumed to be similar to that of the silica beads [8]. The force calibration, depicted in figure 5, can therefore be used to determine the stall forces of the molecular motors transporting the vesicles in the onion cells.

The onion sample is placed in the focus of the optical tweezers setup. The optical resolution of the imaging setup only allows for the imaging of the vesicles and not the cytoskeleton or the molecular motors (figure 6). By observing the movement of the vesicles it can be seen that some vesicles follow linear paths across large distances (many microns) at a near constant speed. It is assumed that molecular motors are transporting these vesicles along the cytoskeleton. In figure 6 two such paths are indicated with the superimposed black lines.

The trap is positioned along the path of the motors and vesicles. The trapping laser's power is increased until a vesicle is trapped, thus stalling the motion of the motor. The results of the stalling forces required is presented in table 1. The y component of the force calibration in figure 5 is used. It is used because it yields a higher trap stiffness value k , and therefore gives an upper bound for the force of the molecular motor.

Again a displacement of 0.5 μm is selected to calculate the stall force from a given laser power and trap stiffness. The average force required to trap a vesicle attached to a molecular motor was measured as 16.8 pN. This is therefore the force required to stall a molecular motor transporting the vesicle. This force is significantly larger than the force required to trap a freely moving vesicle that is not transported along a linear path in the cell (not attached to a motor), 3.39 pN. For vesicles attached to a motor, the trap must overcome the pulling force of the motor

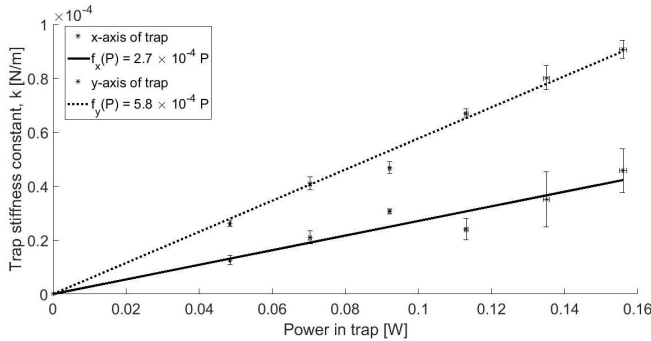

Figure 5. Results of the force calibration for $1 \mu\text{m}$ beads are shown here. The linear fits as a function of the power (P) in the trap for the x and y axes of the trap are $f_x(P) = 2.7 \times 10^{-4}P$ ($R_x^2 = 0.93$) and $f_y(P) = 5.8 \times 10^{-4}P$ ($R_y^2 = 0.99$).

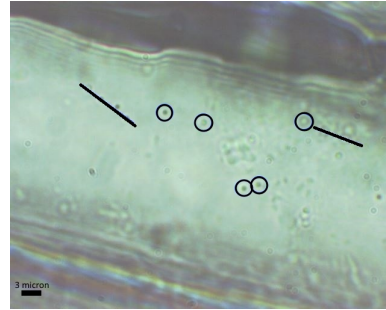

Figure 6. In the still image of an onion cell, examples of vesicles are circled in black and the black superimposed lines indicate paths where vesicles are transported along the cytoskeleton by molecular motors. These are identified, because multiple vesicles follow the same path at near constant speeds.

Table 1. The stall force (component along the y axis of the trap) for vesicles transported by molecular motors is shown for displacements of $0.5 \mu\text{m}$ from the trap center. The force at which the molecular motor recovers and removes the vesicle from the trap is also shown. The average over multiple measurements, using various onion cells, is indicated and the standard deviation is indicated for these force measurements.

	Trapping of vesicles attached to molecular motors (50 measurements)	Trapping of free diffusing vesicles (22 measurements)	Releasing the vesicles from the trap (34 measurements)
Average force [pN]	16.8	3.39	2.66
Standard deviation [pN]	2.57	0.756	1.94
Minimum [pN]	10.0	2.20	1.04
Maximum [pN]	21.9	4.52	6.84

transporting it along its path, whereas for a freely diffusing vesicle not transported along a path, the trap must only overcome the stochastic forces causing diffusion of the vesicle in the cell.

Subsequent to measuring the stall force of the molecular motor, the trap strength is decreased sufficiently such that the motor can move the vesicle out of the trap, and continue on its previous path. This highlights the nondestructive nature of the optical tweezers in that the vesicle is not detached from the molecular motor. It also confirms that it is the motion of the motor that is stalled. The average force at which the vesicle can escape the trap is 2.66 pN . The standard deviation in the results of the stall forces shown in table 1 can be attributed to size variation of the vesicles as well as the number of molecular motors attached to individual vesicles. The relatively large standard deviation can also be attributed to variation of the local viscosity within the cytoplasm since it is non-Newtonian [9], and the viscosity varies locally from that of

water [10, 11] to values a hundred times greater than that of water [12, 13]. This variation in viscosity, in addition to the dense and complex structure of the cytoplasm [14, 15], affects the force required to trap and release a vesicle in the cell and can explain the variation in the results.

4. Conclusion

In this work an optical tweezers setup was constructed and used to investigate the stall forces of molecular motors in onion cells. The forces exerted by the optical tweezers were calibrated using silica beads of 1 μm in diameter suspended in water. Using the power spectrum of the variance of the displacement of the bead in the trap due to Brownian motion, the trap stiffness constant was determined for various trapping laser powers.

Due to the piconewton range of forces that the optical tweezers applies, it is a useful tool to study biological samples. There is a large interest in the biological sciences into the mechanisms and dynamics of molecular motors that transport cellular cargo [1]. In this study, vesicles transported by molecular motors along the cytoskeleton of the cell were trapped *in vivo*. The nondestructive nature of the technique is demonstrated in the release of the trapped vesicle and further movement of the molecular motor that followed. Using the force calibration of the optical tweezers, the force required to stall the molecular motor's motion was found to be in the order of piconewtons which is in agreement with literature [16].

References

- [1] Moffitt J R, Chemla Y R, Smith S B and Bustamante C 2008 *Annual Review of Biochemistry* **77** 205-28
- [2] Ashkin A 1970 *Physical Review Letters* **24** 156-9
- [3] Lodish H, Berk A, Zipursky S L, Matsudaira P, Baltimore D and Darnell J 1999 *Molecular Cell Biology* (New York, NY: W H Freeman and Company) 809
- [4] Visscher K, Gross S P, Block S M 1996 *IEEE Journal on Selected Topics in Quantum Electronics* **2** 1066-76
- [5] Jones PH, Marag OM and Volpe G 2015 *Optical tweezers: principles and applications* (United Kingdom: Cambridge University Press) 34
- [6] Lee W M, Reece P J, Marchington R F, Metzger N K and Dholakia K 2007 *Nature Protocols* **2** 3226-38
- [7] Verkman A S 2002 *Trends Biochemical Science* **27** 2733
- [8] Chandler W L, Yeung W and Tait J F 2011 *Journal of Thrombosis and Haemostasis* **9** 1216-24
- [9] Wayne R 2009 *Plant cell biology: From Astronomy to zoology* (USA: Elsevier) 147
- [10] Kao H P, Abney J R, and Verkman A S 1993 *The Journal of Cell Biology* **120** 175-84
- [11] Bicknese S, Periasamy N, Shohet S B and Verkman A S 1993 *Biophysical Journal* **65** 1272-82
- [12] Keith A D and Snipes W 1974 *Science* **183** 666-8
- [13] Scherp P and Hasenstein K H 2007 *American Journal of Botany* **94** 1930-4
- [14] Fushimi K and Verkman A S 1991 *The Journal of Cell Biology* **112** 719-25
- [15] Jünger F, Kohler F, Meinel A, Meyer T, Nitschke R, Erhard B and Rohrbach A 2015 *Biophysical Journal* **109** 869-82
- [16] Lodish H, Berk A, Zipursky S L, Matsudaira P, Baltimore D and Darnell J 1999 *Molecular Cell Biology* (New York, NY: W H Freeman and Company) 771